

Specifications & Technical Data*

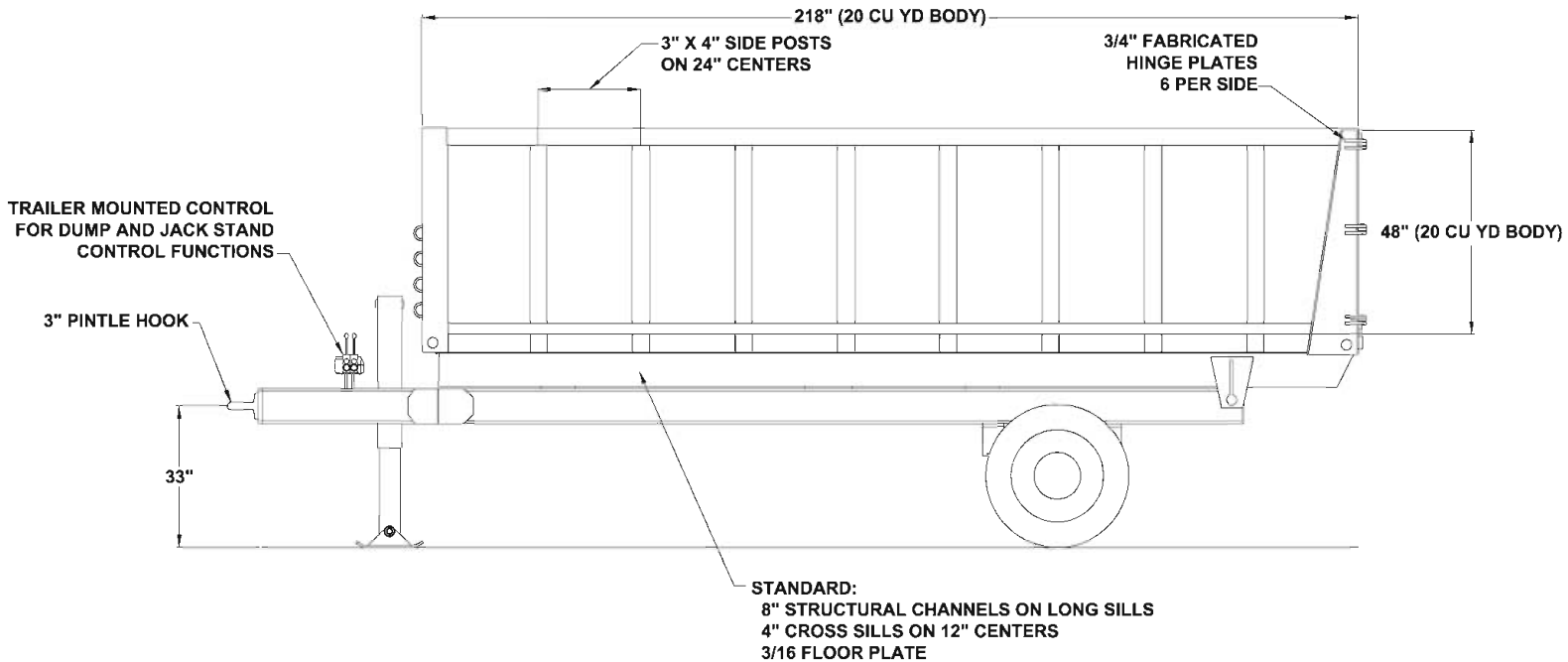

BODY FLOOR	3/16" single sheet steel plate
CROSS SILLS	4" structural channel on 12" centers.
HEADBOARD	10 gauge steel continuously welded to the floor. Top rail is 3" x 4" formed channel.
BODY SIDES	10 gauge steel continuously welded to the floor.
SIDE POSTS	3" x 4" x 10 gauge formed channel on 24" centers. 1/4" steel plate formed rear corner posts.
BARN DOORS	Top and bottom positive locks. Three hinges per door with two 5/8" thick straps.
BODY HOIST	12 ton dual hydraulic cylinder hoist.
FRAME	2" x 8" x 1/4" steel tubing with 6 cross members. Long members are one welded piece from pintle eye to hinge.
SINGLE AXLE	15,000 lb. capacity with dual wheels and tires. Electric brakes are standard. (also available with tandem axle)
DRAW BAR	Vertical load capacity of 15,000 lbs. and 3" pintle eye.
BODY LIGHTS	Meets federal lighting standards. Mud flaps installed behind rear wheels.
PAINT	High grade primer and enamel finish.

All Petersen trailers include manual jack stand mounted on tongue of trailer with sufficient capacity for disconnecting loaded trailer. One control valve is included for operation of hoist. Additional control valve will be included if optional hydraulic jack stand is used. Quick couplers on hydraulic lines and electrical hookup, including lights and brakes.

The Petersen "Lightning Loader" has been the industry standard for economical, quality trash loading equipment for more than 25 years. More than 3,500 units have been tried and tested in over 750 municipalities nationwide and abroad. The Petersen Lightning Loader® has an established track record and a reputation as the highest quality, most reliable loading equipment available.

Petersen manufactures nearly all major components for its Lightning Loader® systems. Truck mounted units are assembled, fully installed and tested at Petersen's plant in Lake Wales, Florida. With complete CNC lathes, machining and fabrication facilities, Petersen is able to control every aspect of production schedule and quality control. The Petersen team of experienced management, sales staff, and manufacturing technicians work hard to provide our customers with the best specialized equipment in the industry.

OPTIONS

- Electronic load covering device
- Manual load covering device
- Twin 10,000 lb. axles
- Air brakes
- Hydraulic jack stand
- Self dump power pack
- 3/16" reinforcement plates between floor and sides
- Continuous welds for side posts
- Six inch dual cylinder hoist (18 ton)
- LED lights

*We reserve the right to change product design and specifications at any time without notice. There may be more specifications than are listed here. Consult your Petersen dealer for complete specifications.



Petersen Industries, Inc.
1-800-930-LOAD (5623)
www.Petersenind.com
local: 863-676-1493
fax: 863-676-6844
4000 State Rd. 60 West
Lake Wales, FL 33859